



AIAA 2001-3433

Unmanned Air Ground Vehicle

M. Janetka, L. Filz, N. Smith, and R.A. Frederick, Jr.
University of Alabama in Huntsville
Huntsville, AL 35899

**37th AIAA/ASME/SAE/ASEE
Joint Propulsion Conference and Exhibit
July 8-11, 2001, Salt Lake City, Utah**

For permission to copy or republish, contact the American Institute of Aeronautics and Astronautics,
1801 Alexander Bell Drive, Suite 500, Reston, VA 20191-4344

UNMANNED AIR GROUND VEHICLE

Melanie Janetka,* Laura Filz,* Nathan W. Smith*, and Robert Frederick, Jr.[?]
Department of Mechanical and Aerospace Engineering
University of Alabama at Huntsville,
 Huntsville, Alabama 35899

Abstract

Early strike forces of the future military are envisioned as being lightly armored to enable a rapid deployment. The increased vulnerability and operational tempo of lightly armored forces evokes the need for beyond-line-of-sight reconnaissance capability under the control of the troops on the ground. The objective of this work is to explore system level concepts that can provide this capability using a combined unmanned air/ground vehicle (UAGV). The study included requirement definition, concept syntheses, and the evaluation of three final configurations to meet the mission requirements. Three integrated product teams worked in a design competition. Engineering students from the University of Alabama in Huntsville and ESTACA participated on the teams. The final concepts included a ducted fans/pulse detonation engine vehicle, a flapping wings concept powered by electric motors, and an ion dive idea powered by advanced fuel cells. An overview of each design is given, as well as a more in depth look at the top ranked proposal.

NOMENCLATURE

BLOS	Beyond Line of Sight
CNN	Cable News Network
FLOT	Forward Line of Troops
IPT	Integrated Product Team
LOS	Line of Sight
Op Tempo	Operational Tempo
PDE	Pulse Detonation Engine
RSTA	Reconnaissance Surveillance and Target Acquisition
UAGV	Unmanned Air/Ground Vehicle
UAH	The University of Alabama in Huntsville
VROC	Vertical Rate of Climb

* Student Member, AIAA

[?] Associate Professor, Department of Mechanical and Aerospace Engineering, Associate Fellow

Copyright 2001 by Robert A. Frederick, Jr. Published by the American Institute of Aeronautics and Astronautics, Inc. with permission

Introduction

UAH IPT Project Background

In high-technology business, companies are using multi-disciplinary teams to decrease product costs and reduce time to market. This approach demands that specialist from diverse backgrounds learn how to work interactively under a set of system-level requirements. Top companies must be able to put together products in conjunction with domestic and international business partners using advanced technologies in a dynamic political/economic environment.

The University of Alabama in Huntsville (UAH) has established an Integrated Product Team (IPT) project to better introduce students to this teamwork environment. The IPT project uses industrial mentors^{1,2} to guide teams of engineering,³ business,⁴ and liberal arts⁵ students in a competitive design project.⁶ Past projects have included a hybrid rocket sub-orbital vehicle,⁷ a tactical missile,⁸ a maglev train, a rocket-launched glider, two advanced rotorcraft projects,⁹ and a crew transport/recovery vehicle for the International Space Station.¹⁰ Details of these projects can also be found at the www.eb.uah.edu/ipt web page.

UAGV Project Introduction

The IPT 2001 project was to design an Unmanned Air/Ground Vehicle (UAGV). The project is a parallel research/education effort sponsored by the U.S. Army Aviation and Missile Command. Three international teams of undergraduate students competed to present the best configuration of a UAGV. The teams consisted of mechanical, aerospace, electrical, computer and industrial engineers from the University of Alabama in Huntsville. They also included engineering students from ESTACA, a college in France. Each team had 15 members.

The IPT project begins with a series of background lectures and meetings among the team leaders and customer representatives to develop a written Concept Description Document that details the requirements for the system. The next semester three IPTs are formed. Thirty four seniors from the UAH Department of Mechanical and Aerospace Engineering, twelve fourth-year students from ESTACA an engineering college in France, and four students from the UAH Department of Electrical and Computer Engineering were distributed among the three teams.

In Phase 1 of the project all three teams worked together to configure a baseline vehicle that attempted to fulfill the project requirements using existing technology. During this phase an assessment of existing vehicles was also made to see how many of the requirements they could meet. This establishes the deficiencies of current technologies and gives the mentors a chance to interact with the students to integrate components of the design process. At the end of this phase, a Review Team consisting of government and industry professionals is briefed. The students present the baseline concept and any recommendations that they have for final revisions to the specification.

For Phase 2, the individual IPTs now work independently to produce three alternative configurations to the baseline. They could include technologies envisioned possible for deployment in the year 2020. The teams each synthesized 3 very different configurations to look at a wide range of possible technologies. At the end of this phase each IPT produced a written document and made a private poster presentation to the Review Team. They presented a description of each concept and an evaluation matrix that showed their assessment of each configuration's attributes relative to the Concept Description Document. Each team used this assessment and feedback from the Review Team to select one of their concepts for refinement in the final phase.

In Phase 3, each team refines their selected concept. This involved making estimates of weight, range, and operating characteristics of their system. It also included developing technology roadmaps for the new technologies that they required. They also developed an outline of programmatic information including a development schedule, project costs, and project production. This information is documented by each IPT in a 50-page proposal.

Each IPT then makes a 20-minute presentation to the Review Team. The Review Team then asks questions based on the proposal and the oral presentation. Each reviewer ranks the proposals based on criteria adapted from the AIAA Design Competitions. The Review Team Chairman then compiles the results and makes the ranking. Five members of the top-ranked team are then invited to present their work at a symposium in France.

PROJECT REQUIREMENTS

The Need

An increased operational tempo is imperative for future forces. As conflicts arise in many different countries, we must be prepared to rapidly move troops and supplies to any location in the world. The op tempo predicted for the next war is 50-100 km/h. This pace is significantly greater than that of World War II and requires vehicles that can move and negotiate terrain at greater speeds. The UAV/UGV is intended for use at the battalion level to assist medium and light forces and increase their effectiveness.

An increase in robotics is essential for the future Army. Due to a reduction in forces, fewer troops are available for service. Additionally, worldwide conflicts require these troops to be able to deploy rapidly to the point of interest. This ability to deploy quickly comes at a price to the soldier. No longer will heavy armor and the supplies that keep a soldier's vulnerability low accompany him. Robotics can augment the power of the troops by performing multiple missions without the risk to human life. The need for robotics exists to fill the gap for "dirty, dangerous, and dull" missions. The use of robotics may even eliminate the need for human forces to perform dangerous missions.

The military wants to prevent casualties whenever possible. The CNN factor, meaning the extensive, publicly followed media coverage, demands a "clean" war for Americans. The UAV/UGV will function at the forward line of troops (FLOT) and beyond the line of sight (BLOS). Reconnaissance missions performed by soldiers on the FLOT are extremely dangerous, and are impossible BLOS. By performing these missions successfully and enhancing the reconnaissance, surveillance, and target acquisition (RSTA) capability of their respective battalions, the UAV/UGV will allow the FLOT to make more informed, and thus, better decisions.

The military's missile and aviation systems must incorporate advanced technologies and robotics to remain viable in the future battlefield environment. A hybrid UAV/UGV fits perfectly into this picture.

The Requirements

The United States Army Aviation and Missile Command (AMCOM) developed a set of notional specifications for a future vehicle that integrates the capabilities of both a UAV and a UGV to perform missions normally performed by soldiers in the field. The requirements for this type of operational capability exist on three different levels. In the most general terms, the UAV/UGV must meet the Army's needs. This need calls for an intelligent, autonomous vehicle that is capable of performing a task. Therefore, the vehicle must be survivable, must be capable of maintaining the operational tempo, and must increase the reconnaissance, surveillance and target acquisition (RSTA) abilities on the battlefield.

On the second level, the vehicle must meet the mission/payload requirements. This involves the vehicle being able to fly to the objective area in 30 minutes in a nap of the earth flight configuration while avoiding both obstacles and potential enemies. Upon reaching the deployment site, it must be able to either hover for 60 minutes or land on the ground and move itself, via ground propulsion, to the designated area. When the mission is complete, the UAV/UGV must then be able to return to its launch area.

Finally, the third level is the vehicle requirements. The vehicle requirements are the actual performance parameters that the UAV/UGV must meet to perform the mission. These involve the vehicle being able to fly at a minimum of 30 km/sec, with a 250 ft/min VROC at a maximum altitude of 4000 ft. An example of how these levels fit in with each other can be seen with this example. The vehicle requirement of being able to have a vertical rate of climb of 250 ft/min enables the UAV/UGV to meet the mission requirement of being able to fly in a nap of the earth configuration. Flying using this profile enables the UAV/UGV to avoid detection and therefore become more survivable.

The challenges to be overcome in this novel system are both technologically and integration based. The technology needed to have a truly "intelligent" system that can monitor, think and actually react to a situation is one of the largest challenges to meet. Artificial intelligence has come a long way, but is still in its infancy. Many communication methods still require the vehicle to be in the line of sight of the monitoring vehicle or the use of an orbiting satellite in order to send telemetry. Tying in the capabilities of a system that can operate in both the air and the ground has the biggest issue of weight. Current propulsion methods are bulky and involve a high

specific fuel consumption. Cutting the weight down with lighter and stronger materials and coupling it with high efficiency engines is the challenge of today and the future of this type of vehicle.

The Baseline Design

The Baseline Design established the limitations of existing technologies in meeting the project requirements. Figure 1 is an artist rendering of the "Pawnee." The vehicle uses 13-foot diameter counter-rotating blade for lift and forward air propulsion. Power is provided by a 100-hp 4 cylinder, supercharged engine. Four rubber wheels each provide ground propulsion driven independently by electric motors driving each wheel. The vehicle has a titanium alloy frame and a carbon fiber composite skin material. GPS and inertial sensors provide guidance and the system only has semi-autonomous control.

Estimated performance included a VROC of 250, a range of 15 km, and a maximum air speed of 30 km/hr. The vehicle had difficulty meeting the requirements of near-quiet acoustic signature and could not meet the requirements for autonomous operation.



Figure 1 Baseline Configuration, The "Pawnee"

The Alternative Concepts

Figure 2 shows the alternative concepts that each team synthesized following the baseline design. This section of the paper will give a summary of the basic air and ground propulsion aspects of each design and the overall rationale of each team's selection of a preferred configuration.







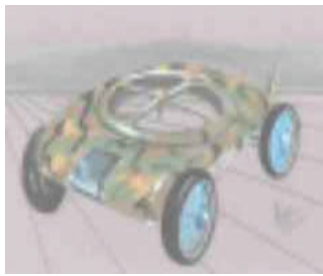

IPT 2001 ALTERNATIVE CONCEPTS – PHASE 3			
TEAM 1			
	Concept 1A - CD1-1	Concept 1B - CD1-2	Concept 1C - CD1-3
TEAM 2			
	Concept 2A - Choctaw	Concept 2B - Blowfish	Concept 2C - <u>Oiseau</u>
TEAM 3			
	Concept 3A - Rotor Racer	Concept 3B - The Moth	Concept 3C - Ionic Defender

Figure 2 Alternative Concepts

Team 1 Alternative Concepts

Design 1A (CD1-1) is a vehicle that uses one ducted fan and four wheels. This concept has one ducted fan powered by a Wankle engine to provide vertical lift. Thrust control is accomplished using four thrust-vectoring ports. A pulse detonation engine will provide the forward flight movement of the vehicle. This design will have four wheels using a suspension system that will allow the vehicle to move over rugged terrain. The vehicle will fit within the constraints of a Hum-Vee trailer and will weigh approximately 350 pounds.

Design 1B (CD1-2) is an electrically powered vehicle with a single, centrally located ducted fan to provide lift. It combines existing aerospace propulsion systems with electricity from fuel cells to provide a hover to full flight profile. In addition to the large ducted fan the vehicle will have 4 small fans to provide directional control and stability for the system. This vehicle will be lighter than the baseline. The vehicle has four wheels with movable struts. The frame and skin of the vehicle will be made out of carbon fiber. It will weigh approximately 550 pounds.

Design 1C (CD1-3) will have three magnetic levitation devices, which use magnetic fields to make an object repel another object. It is a vehicle that uses magnetic levitation device and ion thrust. It uses tracks as its means for mobility on the ground. The ion drive propulsion system will be scaled down to provide the proper amount of thrust. The ground mobility package will consist of two tracks located underneath the vehicle. The body and frame will be made of aluminum, because of its low magnetic properties. This will prevent interference with the magnetic levitation device. It will weigh approximately 300 pounds.

Team 1 selected concept Concept 1A after careful evaluation of all four designs. Overall, the concept was better than the other three even though it lacked in the cost, risk, and schedule of the vehicle factors. This design has some very attractive features such as a lightweight propulsion unit in the pulse detonation engine. Originally the team was going to choose CD1-3 but after researching the magnetic levitation device and the ion drive system it was found that not enough information existed to produce a viable concept. CD1-1 was also chosen because of the forward thinking of the pulse detonation engine and the high efficiency of the ducted fans. These features made the first concept very attractive to the team.

Team 2 Alternative Concepts

Design 2A is a lighter than air vehicle. An inflatable balloon filled with helium will provide lift. Small ducted fans driven by electric motors allow to pitch and yaw; assist in the vertical takeoff and landing so less helium is required. Fuel cells provide electrical power. A hovercraft system driven by an electric fan is used for ground navigation. The hovercraft will be able to traverse water and marsh as well as land. The two side fans will control the forward movement while it is on the ground. The vehicle will feature navigation, sensors, and communications equipment similar to the baseline design.

Design 2B is a modified autogyro. For vertical takeoff, a rotor on top of the vehicle is run to a specified angular velocity range and at the instant of takeoff, power to the rotor is disconnected to eliminate any torque problems during flight. A propeller on the rear of the vehicle provides forward motion through the air. This forward movement causes air to pass over the rotor blades on the top of the vehicle which then rotate and produce lift. While on the ground, the system is carried on miniature tracks similar to those on a tank. A small caster wheel in the front of the vehicle will turn freely. The visual sensor will be a panoramic camera with a 360° view of the battlefield. The communications and navigation systems will be similar to the baseline design.

Design 2C is the flapping wings concept called the Oiseau. The design uses flapping wings and a reciprocating chemical muscle (RCM)¹¹ generates the power for flapping. The RCM is a regenerative device that converts chemical energy into motion through a direct chemical reaction. There is no combustion-taking place nor is there an ignition system required. The RCM is not only capable of producing autonomic wing flapping, but also small amounts of electricity for control of sensors and other electrical components.

According to the results of the Team 3 evaluation, the Oiseau scored highest overall. The Oiseau meets all of the primary requirements, and scored equal or higher than the other concepts in important categories, such as ability to meet cruise speed, ability to meet VROC requirement, and ability to execute the flight profile. In addition, the Oiseau ranks highest in survivability due to its bird-like appearance and its exceptional flight agility. The Oiseau has the most potential for development, as well as the most potential to perform the tasks required while keeping the gross weight of the vehicle to a minimum.

Team 3 Alternative Concepts

Concept 3A, the Rotor Racer, is similar to the baseline, is comprised of a rotorcraft configuration. The design also utilizes a Wankel rotary engine and retractable wheels. Even though this design is similar to the baseline, it weighs approximately two hundred pounds less. The Racer has co-axial, counter-rotating rotors that are made of strong, lightweight materials. The aircraft is built on a monocoque structure that reduces the weight and increases the survivability.

Concept 3B, The Moth, is based on a blended wing body similar to that of the U.S. Air Force B-2 Bomber. This design incorporates two ducted fans for VTOL that pivot along the wing axes to provide forward thrust. No ground robotics were included in this design due to the ability of the ducted fans to provide enough maneuverability for “near earth” configuration. A fuel cell is used as a power source for this system.

Concept 3C, the Ionic Defender, is designed with the purpose of maintaining a low radar cross section and near quiet acoustic signature. The Ionic Defender utilizes ion propulsion for vertical and horizontal flight. The electricity is provided by high capacity fuel cells. The ion engines will be used for hover for near ground activities and for VTOL. Also there will be separate ion engines for horizontal propulsion. The lifting body design will reduce the need for the vertical ion engines during horizontal flight.

Although the Ionic Defender is unconventional, it proves to be the most innovative design that is able to meet most, and exceed many of the requirements set forth by the specifications. Based on its near quiet operation, low power consumption, and stealth-like mobility the Ionic Defender will be capable of completing any mission profile defined by the Army.

The Final Proposals

Team 1 Final Proposal – The XTR-1

This section presents a summary of the final proposal for each IPT.

Solution Team 1 Extreme Engineering has designed a UAGV, the XTR-1, which will meet most of the requirements given by the customer. The XTR-1 will have an elliptical shape to prevent excessive drag on the vehicle. XTR-1’s major systems are the engines, ducted fan, and wheels. The XTR-1 is shown in Figure 3.

The vehicle is fairly lightweight, coming in at around 480 pounds. Also the XTR-1 is capable of VTOL and has a VROC of 250 feet per minute. The vehicle can fly at 30 kilometers per hour during

forward flight. 12 thrust vectoring ports, 6 on either side, provide the VTOL. During forward flight these ports provide directional control for the vehicle. The thrust required for forward flight will be provided by the PDE. The PDE is very small dimensionally and is very lightweight. However even though it is small it provides a great deal of power. The XTR-1 has wings and a tail fin to provide extra lift and stability. The extra lift reduces the amount of power the engines must provide.

The XTR-1 has high ground mobility by utilizing semi spherical wheels on movable struts. These wheels are powered by the Wankel engine and are front wheel drive. The wheels are made from Abs plastic, which is a strong lightweight material. The struts are made from an aluminum-beryllium composite. This material is very strong and can be cast into many shapes.

The XTR-1 has a complete sensor package allowing the vehicle to operate without the payload. The vehicle will utilize radar, acoustic sensing, TF/TA, and communications platforms. The sensors will allow the XTR-1 to operate in adverse weather conditions such as fog or smoke. The communications will allow the vehicle to be capable of LOS and BLOS communications. The primary BLOS communication will be a high frequency band. The vehicle will be semi-autonomous due to the fact that some human interface will be required.



Figure 3 Team 1 Solution – The XTR-1

The pulse detonation engine or PDE is a simple concept with a simple design. The base concept behind the PDE is that it uses a detonation of a fuel air mixture, instead of deflagration that conventional jet engines use. With a detonation, a higher pressure is achieved, which translates in to greater thrust. Since the same amount or less fuel is used to achieve greater thrust, the efficiency is a good deal higher than that of even ram jets. The PDE has a theoretical

ISP efficiency of 20-30% improvement over the performance of ramjet technology.¹² In addition to greater efficiency the unit is also lighter than its conventional counterparts, which endears it self to this project. The actual machine workings are slightly more complicated. However, it is still far less involved than the standard jet engine.

The control and sensor equipment must be controlled completely by computer to achieve the small timing tolerances. The injectors must be time coordinated with the exit of the detonation wave from the detonation chamber, and the predetonation. This also means that only hi-performance injectors and ignition equipment can be used. The sensory equipment is the key to the precision control system. The constant monitoring of the PDE's performance allows for nearly instantaneous corrections.

The weight of the propulsion system is another major factor in the weight of the vehicle. The overall weight of the system, which includes the PDE and the Wankel engine, is 125 pounds. This is one of the major sources of weight for the XTR-1. Extreme Engineering is hopeful that the weight of the propulsion system will significantly decrease by 2025, however the vehicle will still work even if this does not occur. Table 1 shows a breakdown of the weight from each of the propulsion components.

Table 1. Propulsion Weight

Weight	
Wankel Engine	20kg
JP-8 for Wankel	11.8kg
JP-8 for PDE	30.2 lbs
Battery	4.5kg
PDE Engine	15 lbs.

The Wankel Rotary engine is a low weight, high efficiency, and internal combustion engine. The purpose of the Wankel in the selected design is to provide the vertical lift upon takeoff, landing, and hovering. The Wankel will run on JP-8 fuel, which is readily available today for military use. Figure 4 shows a schematic of the Wankel engine.



Figure 4. Wankel Engine

The pulse detonation engine (PDE) is being evaluated and developed as a potentially high-payoff new aeronautical propulsion system. The PDE represents a potential propulsion technology leap beyond the gas turbine engine.

Based on the results of several studies to date, the air-breathing PDE offers potential performance and life cycle cost payoff for both subsonic and supersonic vehicle applications. Potential applications of interest are propulsion systems for tactical aircraft (manned or unmanned), missiles and subsonic/supersonic propulsion source for future hypersonic aircraft.

In PDE, core jet engine components such as fans, compressors, and turbines are not required. This will decrease engine weights and increase engine reliability. Moreover PDE technology maximizes the distance a plane can travel on a given amount of fuel. The time required for detonation development has been measured as a function of fuel type, equivalence ratio, initial pressure, dilutents type, and dilutents concentration.

It has been estimated that in order for the PDE cycle to be competitive with conventional turbojet/turbo ramjet systems, they will be required to operate in the 75 to 100 Hz range with near stoichiometric fuel/air mixtures. This represents a cycle time of approximately 10 msec, requiring a propellant refill time in the 5 msec range.

Developing compatible air induction systems that will satisfy the above requirements, as well as provide adequate sealing from the high pressure- high temperature exhaust products, represents a major technology challenge.

Until such time as actual PDE are on test stands, calculated performance number are only estimates. However, in an effort to address realistic performance, the fill valve coefficients have been

estimated at 80% and realistic component efficiencies have been used. The airflow is injected through choked flow rotary valves into the combustion chamber.

Frequencies in the 70-100 Hz range are also assumed to be possible (an engine design study estimates that these frequencies are possible, but at a upper end of possible frequencies for annular designs)
PDE thrust is a direct function of engine volume and operational frequency.

A shock trap boundary-layer bleed system is used to help stabilize the terminal shock train. A major feature of the diffuser is a center body, which allows a conservative area distribution, and acceptable flow angles. The diffuser also includes a plenum aft of the center body, just forward of the engine face, to dampen engine-induced pressure waves.

The detonation chamber is a cylindrical tube about 9cm. long and 6cm. in diameter. Attached to this tube is an injector and a predetonation cylinder. The injector is equipped with an atomizer so the JP-8 fuel is more easily detonated. The predetonation cylinder is a smaller cylinder where the ignition of a small amount of fuel and oxidizer is preformed. In this smaller tube the fuel/oxidizer is in a state of deflagration which is converted to detonation. The resulting detonation wave enters the detonation chamber which in turn detonates the fuel/air mixture. The predetonation cylinder is used for two distinct reasons, that both mean higher pressure. Less Fuel/oxidizer, which burns hotter, can be used, and the pressure needed for the deflagration to detonation transition is easier to obtain in the smaller tube. The ignition in the predetonation cylinder is started by an electrical spark. These operations are done at 100Hz. For this reason precision timing is critical. Figure 5 shows a generic diagram of a PDE engine.¹³

While the exact numbers of the latest prototypes are not available there are some things that are known. For instance, the Navy has been working to run PDE's of heavier fuels.¹⁴ Also, higher pressures have been achieved in many tests. Based on pressures seen in these tests the thrust can be calculated at 50% greater than the model represented in appendix D.¹⁵ From the base model several advancements are expected. The use of JP-8 fuel is expected to become a standard practice in the Navy. Fuel efficiency will most likely improve with experience, as most developing systems do. Also, the relatively low weight of 30.2lbs, has the potential to reduce as much as 5 or 6lbs. Lastly the aforementioned increase in pressure

will yield greater thrust. For all these reasons the pulse detonation is a prime choice for this design. Detonation in the PDE is a form of combustion that differs significantly from deflagration, the type of combustion found in conventional gas turbine engines, pulse jets, and rockets. Deflagration is characterized by subsonic wave speeds, whereas the detonation combustion process occurs at high supersonic wave speeds relative to the unburned reactants (approximating Chapman-Jouquet C-J conditions). The detonation acts as an aerodynamic piston as it travel through the reactants gas mixture, raising the useable pressure by a factor of 7 to 8. This constant volume combustion process is thermodynamically more efficient than the constant pressure deflagration combustion process and provides greater available energy for performing useful work.

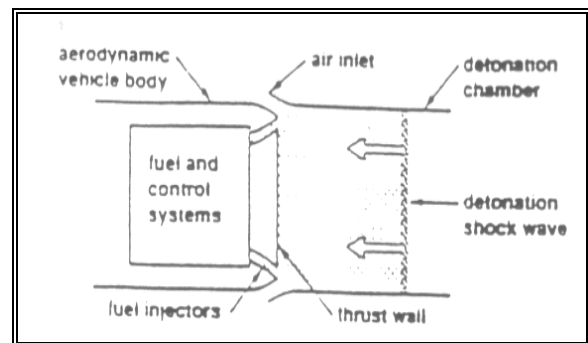

Figure 5. PDE Schematic

Team 2 Solution – The Oiseau

The Oiseau, a French word meaning bird, is a UAGV capable of meeting the future needs of US military forces. Utilizing an efficient design and mating together both technology and simplicity, the Oiseau meets the need of providing direct intelligence support during dirty, dangerous, and dull missions.

Forward intelligence support is the essence of the Oiseau's capabilities. Using a Fuel Cell system, the Oiseau is able to fly without the noise associated with most motors. As it produces power for the four flapping wings, it also produces the electricity needed to power the on-board navigational, surveillance and communication equipment. With only water as a by-product, it is also an environmentally sound energy production system. The "intelligent" sensor and communication package allows constant beyond line of site (BLOS) communication to the soldiers viewing, in real-time, what the sensors on the Oiseau see. The flapping wing configuration allows the Oiseau to fly with agility only matched by real birds

and flying insects. On the ground, most any terrain can be traversed with a tracked system, configurable by the soldiers for wet, dry or slippery conditions, that is able to move at 5 mph. Both on the ground and in flight, an active camouflage system makes this near silent vehicle almost invisible to the naked eye as it blends in with its surroundings. Damage to the internal components, outer shell or wings of the Oiseau are easily replaced because all of these components are modular and thus easily removed and replaced/repared.

The capabilities of this UAV/UGV are what make this vehicle stand alone as the future of intelligent robots for military use. Each component on its own is noteworthy, but the compilation of them in one system makes the Oiseau extraordinary. A couple of the most noteworthy components are first, the propulsion system. Because fuel cell systems are becoming more efficient and provide quiet power, it was the logical choice for a system that needs a near silent acoustic signature. It produces power without combustion, which keeps the thermal signature low, and runs on a minimal amount of fuel. It is coupled with the next noteworthy component; the extremely lightweight wings made with titanium and Gore-Tex. These wings can be actively twisted and bent using piezoelectric materials along the wing's edge and allowing the flight characteristics of the wing to change instantly. Figure 6 shows an artist rendering of the Oiseau.

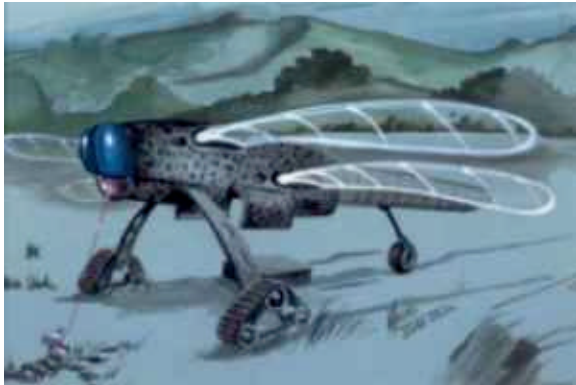

Figure 6. Team 2 Solution.

The propulsion system of Oiseau is divided into three main parts: the energy's production, the motor and the transmission of the power to the wings. The energy is provided by a fuel cell, using hydrogen as fuel. The electricity produced can be used either for the electrical motor generating the flapping motion, or for the ground robotic system. Then the

transmission system converts the spinning movement into an "up-and-down" motion.

Approach

In order to design a relevant propulsion system, we focused, during our researches, on several requirements that it should fulfill. First the Oiseau has to be as noiseless as possible, and second, the energy used has to be readily available in 25 years. These are the reasons why we decided to use an electric motor. Once this choice made, the challenge was to find a source of electricity neither too heavy nor too big. Traditional batteries are not convenient because the power needed would require many batteries. Such a solution would have been too big, in term of volume, and also too heavy. Considering all the research and progress done during the past few years, fuel cells appear very promising and it will overcome these problems. Furthermore, and that was part of our requirements, this technology is now under development, a lot of private companies invest money in this research. Many automotive manufacturers are racing to be the first to bring a fuel cell vehicle to the marketplace. Automakers and component suppliers are spending billions of dollars to drive fuel cell technology toward commercialization. We can reasonably expect that in 20 years, all these researches will be completed and progress done.

In principle, a fuel cell operates like a battery. Unlike a battery, a fuel cell does not run down or require recharging. It will produce energy in the form of electricity and heat as long as fuel is supplied. A fuel cell consists of two electrodes sandwiched around an electrolyte. Oxygen passes over one electrode and hydrogen over the other, generating electricity, water and heat ¹⁶ Figure 7 shows a diagram of how the fuel cell works.

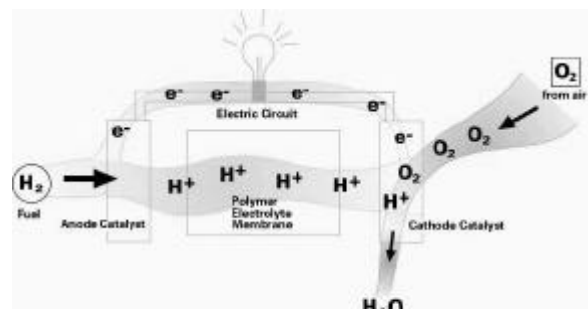

Figure 7. Fuel Cell

Hydrogen fuel is fed into the "anode" of the fuel cell. Oxygen (or air) enters the fuel cell through the cathode. Encouraged by a catalyst, the hydrogen atom splits into a proton and an electron, which take

different paths to the cathode. The proton passes through the electrolyte. The electrons create a separate current that can be utilized before they return to the cathode, to be reunited with the hydrogen and oxygen in a molecule of water. This is shown in Figure 8.

A fuel cell system, which includes a «fuel reformer», can utilize the hydrogen from any hydrocarbon fuel - from natural gas to methanol, and even gasoline. Since the fuel cell relies on chemistry and not combustion, emissions from this type of a system would still be much smaller than emissions from the cleanest fuel combustion processes.

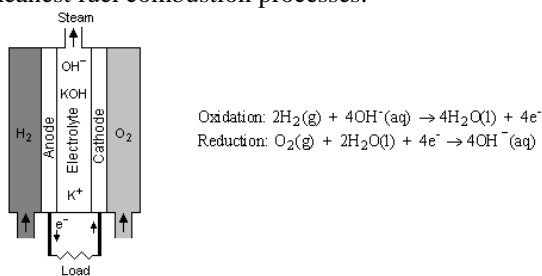

Figure 8. Combustion Process

Not only do they produce reasonable efficiencies in 30 kW sizes; they will likely be able to run quietly, need infrequent maintenance, emit little pollution and have high efficiency even at part load conditions. Electricity is used by many of our modern high technology devices. Presently, batteries are used in these devices. Batteries do not have a long enough life for these applications. Fuel cells could provide continuous power for these devices. Every week or month a new supply of liquid fuel would be injected into the fuel cell.

Fuel cells are being proposed to replace Otto or Diesel engines because they could be reliable, simple, quieter, less polluting, and have even greater economy. Fuel cells are most ideal for electric power production because electricity is both the initial and final form of energy that is produced.

Fuel cells are still a few years away from commercialization on a large scale because there are still some problems to be solved. However, if these problems are addressed, fuel cells will become predominate propulsion method in the future. In the last year there has been considerable progress made in this direction.

Now, thanks to the progress done, fuel cells reach characteristics of weight and compactness compatible with our requirements: 1kg/kW and 1dm³/kW.¹⁷

Considering the power required by the motor which is 34.5 kW, the fuel cell needed for Oiseau will weigh 35 kg (67 lbs.) and its volume is 35 dm³.

As companies who build these fuel cells design them for the specific automotive field, there are still no fuel cells fitting the exact characteristics of Oiseau.

Arthur D. Little says, "The opportunities for further improvements in PEM fuel cell technology are impressive, further emphasizing the potential role of the technology as a major worldwide standard beyond 2000."¹⁸ Fuel cells can promote energy diversity and transition to renewable energy sources. Hydrogen-the most abundant element on Earth- can be used directly.

Carbon nanotubes are a new method for the storage of hydrogen. One way carbon can arrange itself is in a sheet pattern like a honeycomb. This is the graphite form of carbon. The sheets are not bound tightly together, but if they are wrapped on top of each other, a very strong carbon nanotube is formed. Terry Baker, professor of chemistry at Northeastern University discovered carbon nanotubes, while Terry was doing research at the Atomic Energy Authority in Harwell, England. The carbon was a waste product of catalytic reactions. As a catalytic reaction proceeds platelets of precipitated carbon stack below and above the metal particle. Different metals of course, produce different configurations of the platelets. The carbon may stack like crackers, some may stack slanted end to end resembling a herringbone, and some may stack in a bent formation creating tubes. A consistent property of the nanofibers is that the distance between each platelet is identical. The fibers are generally 5-100 micrometers in length and have a diameter of 5-100 nanometers, hence the name carbon nanotube. It has also been discovered that treating the nanotubes with nitric acid will open the caps on the end of the tubes. The interesting part concerning these carbon nanotubes is that their widths are just large enough for hydrogen molecules but too small for larger molecules. A typical hydrogen molecule consists of two hydrogen atoms. The hydrogen atom has the second smallest radius of all elements because its one electron is in the first orbital, which is the closest orbital to the positively charged nucleus. So the one electron is held very tightly to the nucleus thus decreasing the atomic radius. It is possible then that perhaps hydrogen can be stored in these carbon nanotubes.

Terry Baker realized the possibility of storage in carbon nanotubes. His research findings have produced astounding results they have been able to store 30 liters of hydrogen in one gram of carbon! This corresponds to approximately 75% hydrogen storage by weight. At this rate a 25-liter tank which is half the size of a gasoline tank and weighs 87-kg can

power a car for 5,000 miles. These experiments have been repeated fifty times by Baker.

The following general process is followed to allow hydrogen to be stored in the carbon: The nanotubes are first washed in acid to remove any metal impurities, they are then heated to 900 degrees C and put under a vacuum to remove any gases that may be slits on the nanofibers. Hydrogen is then pumped into the system at a pressure of 120 atm. The hydrogen can then be released by gradually reducing the pressure. Note a pressure of 40 atm must be applied to keep the hydrogen in place. The pressure where the hydrogen gas will cease to be released from the carbon tubes has also yet to be determined.¹⁷

Assumption: considering that a 25 liter tank which is half the size of a gasoline tank and weighs 87 kg can power a car for 5,000 miles. And that an electrical engine of such a car required 33 kW (Toyota's Prius). Oiseau needs the same power but the mission requires it only to be able to do 36 miles (75 km). Fuel cells produce electricity. This is not the desired form of energy for transportation. The electricity must be converted into mechanical power using an electric motor. The power required at the output of the motor for the flapping wings is 32.2 hp. Here are the references of the motor that we chose: it is an engine designed by the company BLADOR.¹⁹

This motor weighs 60 kg (132.3 lbs.), but we can expect the within 20 years the electrical motor's weight will be reduced by 10 to 20%²⁰, so we based our calculation of weight on the value of 112 lbs. The output of the motor is a rotation speed on a shaft; we need to convert this motion into an up and down motion, so that our wings will flap. Figure 9 is not at scale, but shows the principle of our transmission system.

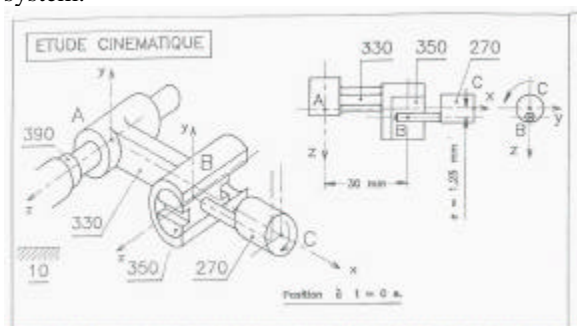

Figure 9. Principle of Transmission

Team 3 Solution – The Patrocinator

The Patrocinator has been created to meet all of the requirements set forth in the specifications from AMCOM. The Patrocinator is shown in Figure 10. Patrocinator will get you there, will let you know what

is out there, and will return safely faster, cheaper, and with higher performance than its competitors. This UAGV uses a completely silent ionic propulsion system that is powered by the next generation of fuel cells. It incorporates the use of an exoskeleton framework structure for a reduction in weight as well as for improved survivability. Sensors are imbedded into the skin to minimize housing components. The skin itself is comprised of layers of radar reducing material alongside high strength materials. The UAGV has good ground mobility and excellent communication with home base. Uniquely setting itself apart from its competitors the Ionic Defender has a top down thinking process utilizing the best compilation of information gathering available. It's obvious. The Patrocinator delivers. Yes, it challenges its design team to package this cutting-edge vehicle for reliability but the system uses technology that is already out there in some form thereby minimizing overall costs for development.

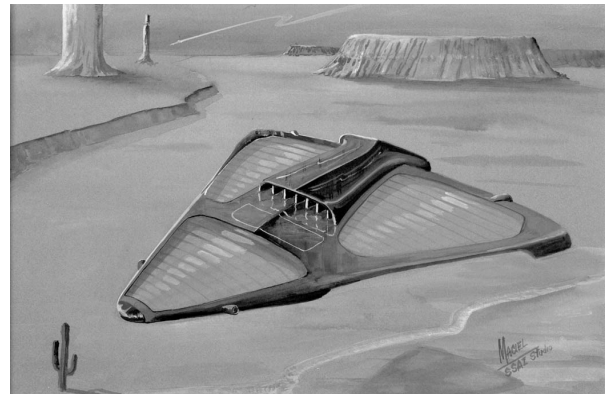

Figure 10. Team 3 Solution

Money is a good place to start in describing the key features of the Patrocinator. For an estimated cost of 170 mil in today's U.S. dollars the U.S. Army can have all of their needed capability by the year 2020. It's not the cheapest on the market but it is far from the most expensive. What AMCOM gets for its money is a vehicle that will change the face of warfare forever. Our soldiers will be protected well behind the front line while a swarm of Ionic Defenders communicate vital information about the enemy in real time back to home base. This comes at a fraction of the cost of some of the military's other high-tech ventures.

The Patrocinator brings to life ionic propulsion. This unique propulsion system has never been used in a military application before, but this system has no moving parts, no emissions, and minimal power requirements. Screens are used to charge air particles

in the ducts and accelerate them out the back of the vehicle, in turn propelling the Ionic Defender quietly and effectively to its destination.

Fuel cells are the propulsion method of choice for the Ionic Defender. The decision to use fuel cells came about from the power to weight ratios that burdened the baseline design. Ultimately, fuel cells are being heavily researched at this time both by the military and commercial venues and they offer the best power in the smallest sizes and the cheapest costs.

Top down thinking is the only way to go. It is a feature that doesn't increase costs or complication. It is a methodology that raises reliability immeasurably and lends itself to the thought processes of the military operators who will be handling the Patrocinator. This thought process is unique to the Patrocinator, and developed solely by GRAD Inc. for the purpose of this unmanned vehicle. The processes are based on requirements set forth in the specification. The advantages that Patrocinator brings to the table continue with the choice of materials for fabrication, aerodynamic design, and ground mobility.

Propulsion

The concept of ionizing air to produce a flow has existed since the 1950's. This technology derived from electro-static air cleaners. A high voltage potential is placed across two grids; the voltage potential ionizes the surrounding air and causes it to flow through the grids. The second grid is the collecting grid; the grid attracts solid particles to it. The system easily removes significant amounts of airborne microscopic debris, thus providing cleaner air.

Alexander P. de Seversky patented an electro-static system for propulsion in 1964. Seversky created a large, lightweight structure applying the above technology. He proved that enough lifting force could be produced to sustain flight of a heavier than air vehicle.²¹

GRAD Inc. chose ionic propulsion because of its quiet operation and low power consumption. The electro-static system produces no sounds except for the flowing air. This quality provides the vehicle with a lower chance of detection by enemy due to noise. In an article written about Seversky's invention the author claimed, "It sat there silently in midair."²² Also, the system requires relatively low power use. This system when compared to a conventional rotorcraft design uses half the power to provide the same lift. Another benefit of the system is that it is less susceptible to damage from projectiles than a turbine or ducted fan. If a bullet is shot

through the grids only a few wires may be damaged, but the remaining wires can still operate the vehicle.

The ionic propulsion system consists of a high voltage pulse generator connected to two grids or arrays of wires. A short distance of about four to six inches separates the grids. The top array has an emitting area approximately twenty times smaller than the receiving array. The voltage generator sends a varying positive charge to the top grid, while the bottom grid receives an equal negative charge. This voltage potential ranges from 50kV to 150kV. The surrounding air is ionized and pushed through the duct encircling the arrays. The force exiting the engines is adjusted by varying the voltage potential across the grids; the higher voltage produces more thrust. This allows the vehicle to lift from the ground, to a hover profile, and to a full flight profile. The source for horizontal thrust will be a smaller version of the engine mounted vertically. This engine will duct the airflow similar to a turbojet engine to add additional power.

Preliminary calculations have determined that the power required for the ionic engines is only 25kW. This is powerful enough to allow a VROC of 250 feet per minute. The horizontal engine will give a speed of 50 kilometers per hour.

Although this technology is not widely known, the ionic propulsion system is an easily constructed system. There is little maintenance needed; the system does not have any moving parts to wear out or breakdown. With little investment in development of the engines, there is the possibility of revolutionizing the propulsion industry.

Technical Comparisons

Table 2 summarizes the key characteristics presented by each of the teams. It also shows the key enabling technologies that will need investment to realize the implementation of the concept.

Table 2. Team Comparisons

Comparison Criteria	Team 1 Concept	Team 2 Concept	Team 3 Concept
Air Configuration	Ducted Fans, Wings	Flapping Wings	Ionic Propulsion
Ground Configuration	Semi-spherical Wheels on movable struts	Matracks	Ionic Propulsion, Landing Struts
Payload Mass, kg (lb)	(27.2) 60	68 lb	60 lb
Gross Takeoff Weight, kg (lb)	(218) 480	332 lb	300 lb
Energy Source for Air Transport	Wankel Engine (hover), PDE (Forward Flight)	Fuel cells	PEM Fuel cell
Energy Source for Ground Transport	Wankel Engine	Fuel cells	PEM Fuel cell
Hovering Power, kW (hp)	83.5(112)	35 kW(47 hp)	22 kW(30 hp)
Cruise Power at 15 km/hr , kW, (hp)	74.5 (100)	7.4 kW	23.8 kW
Total Energy for Mission Profile, KJ (BTU)	1.079x10 ⁶ (1.023x10 ⁶)	299,259 kJ (283,631 BTU)	2.564x10 ⁵ kJ (2.43x10 ⁵)BTU)
Basis of Autonomy	Computer	MACC	Thinking process
Primary BLOS Method	HF band	“Spy Oiseau”	Ultra-Wide Band
Primary Structural Material	Titanium, ABS plastic	Magnesium and Carbon Fiber	Carbon Fiber
Enabling Technology 1	PDE using heavy fuels	Fuel Cells and Electric Motors	Ionic Propulsion
Enabling Technology 2	Muffler Technology for PDE	Piezoelectric Material	Fuel Cells
Enabling Technology 3		Wing Material	Ultra-Wide Band
Enabling Technology 4		Chip on Flex Sensors	Vehicle Skin
Structure	Titanium	Magnesium Alloy and Carbon Fiber	Carbon Fiber
Fuel Weight		1.6 lbs	
Range		75 km	30 km

Selection of the Preferred Concept

An Industrial Review Team selected the concept of Teams 2 as the best overall design. The reviewers made their evaluations based on a 50-page report and an oral presentation by each team. The used evaluation criteria based on the AIAA Design Competition that had been modified for this specific contest. The evaluation criteria included: technical content, organization/presentation, originality, and feasibility. Since the specification allowed a deployment in the year 2025, the teams could project technologies in their presentations.

The Review Team liked the use of the Wankle engine to provide power for both the air and ground mode on the Team 1 design. The technology projections were clearly presented and the report presented in a logical sequence. Challenges in driving the ducted fan and the wheels with the same RPM engine were noted

along with the acoustic signature of the pulse-detonation engine.

The Review Team liked the bold, imaginative approach of team 2. The saw their reports was concise and well written. The concept also maximized the use of available development time to achieve the technology advances. They liked the electronic drive the operations scenarios given. Challenges in mitigating the technical risk and the stability of the platform were concerns.

The Review Team though that Team 3 had a novel approach to the customer requirements. The concept had a good mix of the state of the art with reasonable expectations for future technology development. The presentation of the material did not make clear the state of the art in ion propulsion and did not have a cohesive style. The use of ion propulsion for the

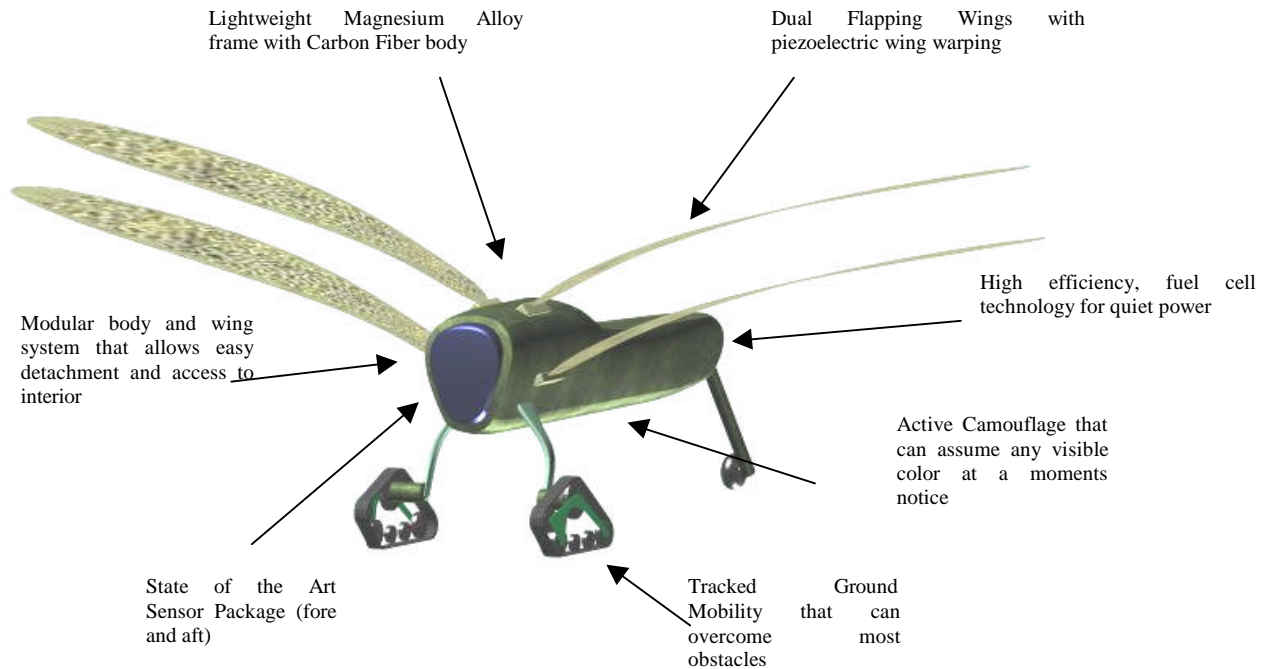

Figure 11 Key Features of the Oiseau

ground mobility fulfilled the basic operational requirements

Based using the evaluation criteria the Review Teamed named Team 2’s proposal for the Oiseau as the top concept. The teams were all commended for their novel ideas and broad look at possibilities for fulfilling the project requirements.

Implementation of Preferred Concept

Figure 11 shows the features of the Team 2 Oiseau. The vehicle is 16 feet wide and 5 feet long.

Operations Scenario

The assumed mission profile is for the vehicle to takeoff vertically close to the FLOT, climb at 250 fpm to a maximum altitude of 500 ft AGL (at high hot conditions), and cruise at 30 km/hr for 30 minutes (15 km range). The vehicle will then either hover for 60 minutes or land, traverse the ground, and takeoff again and then fly back to the departure point. The sensor package and payload capacity will give the Oiseau considerable flexibility in terms of the operations it can perform.

Performance

Table 3. Final Concept Evaluation

CDD Requirement	Requirement	Assessment
Range from launch point	15 km	30 km
Cruise Speed	30 km/hr	40km/hr
VROC	250 ft/min	360 ft/min
VTOL Capability	Yes	Yes
Payload:	60 lb	68 lb
Operational Altitude	0 to 500 ft AGL	0 to 500 ft AGL
Hover to full flight profile	Yes	Yes
Operation	Autonomous or Semi-autonomous	Autonomous or Semi-autonomous
Acoustic Signature	Near Quiet	Moderate to Near Quiet
Communications	BLOS	BLOS
Deployment	2025	2025

The Implementation

There are several technologies whose further development is critical to the development of the

Oiseau. One such technology is lightweight fuel cells and electrical motors. Fuel cells have been used for quite some time in spacecraft for the generation of electrical power; however, some adaptations are needed for the Oiseau. Although operating characteristics of electric motors are widely understood, a specific motor will have to be developed that is optimized for flight (i.e. high power to weight ratio, etc.). Another technology currently under development is Integrated Vehicle Health Management (IVHM). This is a computer software system that records: fault messages with Line Replaceable Units (LRUs) isolation, parametric and performance data, and warnings, cautions, and advisories.²³ This system can be used not only to schedule preventative maintenance, but to optimize sub-system performance as well. Another technology required is piezoelectric materials to be used by the control system. These materials, also currently under development, distort their shape when voltage is applied to them. Such devices will be built into the flexible wings. This will yield control over camber for aerodynamic effects and wing warping for controls.

Further technological development required includes wing material and lighter structural materials. The requirements for the wing material are unique. Directional gas permeability is required for aerodynamic reasons. There exist fabrics capable of such characteristics; however, better performance is, of course, needed. Lighter materials in general could greatly effect the performance characteristics of the Oiseau. Current research in this topic is broad and the shows much potential.

The next area of study needed is the development of software that can handle the autonomous operation of a UAGV. There is considerable development of software in the commercial arena. Advance avionics packages should be developed to control the vehicle as it flies as well as coordinate the ground robotics. There are considerable advantages to using flapping wing flight. However, there is considerable research work needed to fully implement the design. With an anticipated deployment date of 2025, there is ample time to complete supporting research. With this intended deployment date, detailed design will need to occur by 2016. The technology must then be available by this date to fulfill the specification. More specifically, the electrical propulsion system's research should be completed in the next 10 years (by 2011). The research for the wing material must be done in the next 12 years as well to allow for testing before detailed design begins. The software should be developed by 2011 as well and tested in an

existing vehicle before 2014. The avionics should be developed in parallel with the software. The combination of the software and avionics should be tested before 2016.

Acknowledgements

The project was supported with a grant from the U.S. Army Aviation and Missile Command. The contract managers were John Fulda and James Winkeler. Sverdrup Technology provided support for an Open House Event. The Redstone Chapter of the American Helicopter Society sponsored an awards luncheon to recognize the students. The UAH Student Government Association provided money for student travel. Marie-Sophie Pawlak at ESTACA provided financial support for travel.

This project involved forty-four students from UAH and ESTACA who worked on the integrated product Teams including: Akmal Abdulakhatov, Cyril Augier, Jason Back, Majed Batais, Ben Bramblett, Segolene Branstchen, Kevin Buch, Jean-Emmanuel Bzdrega, Joe Caldwell, Shane Canerday, Younes Elkacimi, Laura Filz (Team 1 Leader), Julien Geffard, Brian Griffin, Timur Hakimov, Timothy Hardin, Matthew Harris, Damon Hay, Chris Hirstein, Francois-Xavier Hussenet, Pierrot Ivoula, Melanie Janetka (Team 2 Leader), Jon Kilpatrick, James Kodrowski, Sebastian Kriner, Kannathas Krishnassamy, Shane Lackey, Sheree Long, Kristopher McDougal, Jason Newton, Angeline Nuar, Demetrius Peoples, Rajat Sharma, Nathan Smith (Team 3 Leader), Richie Sparkman, Linda Taylor, William Thomas, Cedric Trophard, Cederic VanEssen, Nicholas Vergenealt, Pascal Vidal, Timothy Weaver, Virgil White, Khalid Zarouni.

AMCOM personnel participated as mentors giving brief lectures to the class and serving as consultants throughout the project. They were John Berry, John Carter, Jim Dingess, John Fulda (Lead), Jim Kirkwood, Pat McInnis, Alfred Reed, Jim Winkeler (Co-Lead), and Virginia Young.

Mentors from other companies include: Sherry Adlich (Teledyne Brown Engineering), Phillip Farrington (UAH-ISE Dept.), Frendi Kader (UAH-MAE Dept.), Alex Maciel (SSAI Sigma Services of America, Inc.), John Piccarillo (UAH-ECE Dept.), Jim Sanders (UAH Propulsion Research Center), George R. Smith (Smith Enterprises).

The Design Review Team consisted of Industry Experts as follows: Lawrence Bavis (CAS Inc.), Dr. Henry L. Pugh (The Boeing Company), Dr. M. Frank Rose (NASA MSFC), Jan VanAken (NASA Ames),

Mr. David Weller (AMCOM AMRDEC – Lead), Dr. Virginia Young (AMCOM).

The following people served active support roles in developing Internet communications and administrative support for the class: Alex Maciel Bob Middleton, Ina Ryzhkova, Ilya Shkolnikov, James Williamson, Beth Floyd, Brandy Carder, Suzi Bonn, and Sarah Paul.

The following faculty lead classes that were integrated together for this project Dave Berkowitz, Administrative Sciences; Paul Componation, Industrial and Systems Engineering; Charles D. Corsetti, Electrical and Computer Engineering; Robert Frederick – Lead, Mechanical and Aerospace engineering; Rose Norman, English; Marie-Sophie Pawlak, ESTACA International Director; Dawn Utley Industrial and Systems Engineering; and Earl Wells, Electrical and Computer Engineering.

References

- ¹ Frederick, R. A., Jr. and Sanders, J., "The Effective Use of Mentors in Undergraduate Design" 1993 ASME Winter Annual Meeting, AES Vol. 30/HTD Vol. 226, Thermodynamics, Analysis, and Improvement of Energy Systems, pp. 219-225, New Orleans, November 28 to December 3, 1993.
- ² Frederick, R.A., Jr., Evans, D.A., and Norman, R.L., "Multi-College Design Class with Industrial Mentors," 32nd AIAA/ASME/ASEE Joint Propulsion Conference and Exhibit, Lake Bunea Vista, FL, AIAA Paper No. 96-2560, July 1-3, 1996.
- ³ Frederick, R.A., Jr., Evans, D.A., and Norman, R.L., "Multi-Agency, Integrated Product Teams," paper accepted by Stanley L. Proctor, ABET President Elect, Innovations in Engineering Education, Accreditation Board for Engineering and Technology (ABET) 1996 Annual Meeting, San Diego, CA; October 31 to November 1, 1996, pp. 165-171.
- ⁴ Frederick, R.A., Jr., Evans, D.A., Norman, R., "Integrating Business and Engineering Education," Invited Panel Discussion, Decision Sciences Institute, 27th Annual Meeting, Orlando, FL November 24-26, 1996.
- ⁵ Norman, Rose, and Frederick, Robert A. "Integrating Technical Editing Students in a Multidisciplinary Engineering Project." Technical Communication Quarterly 9.2 (Spring 2000): 163-89.
- ⁶ Frederick, R.A., Jr., Takada, P., and Cook, L., "Prototype for a Multi-National Propulsion System Design Course," AIAA Paper 2000-TBD, AIAA/ASME/SAE/ASEE Joint Propulsion Conference and Exhibit, July 16-19, 2000.

⁷ Paxton, J., Achenbach, Patterson, P., M. Pyburn, J., Thomas, M., and Frederick, R. A., Jr., "Design of Turbopump-Fed Hybrid Launch Vehicle," AIAA 93-2549, AIAA/SAE/ASME/ASEE 29th Joint Propulsion Conference and Exhibit, Monterey, CA, June 28-30, 1993.

⁸ Sims, J.D. and Frederick, R.A., "Preliminary Design of a Hybrid Propulsion System for a Multi-Mission Missile System," March-April *AIAA Journal of Spacecraft and Rockets*, 1997.

⁹ Frederick, R.A., Jr., Davis, K., Hopper, M., and Symes, A., "Preliminary Design of Rotorcraft with Multi-Disciplinary, International Teams," AIAA Paper No. 99-2845, June 20-23, 1999.

¹⁰ Thomas, S., Bollich, J., Popo, M., and Frederick, R.A., Jr., "International Space Station Crew Transfer/Recovery Vehicle," AIAA Paper AIAA-2000-3741, AIAA/ASME/SAE/ASEE Joint Propulsion Conference and Exhibit, July 16-19, 2000.

¹¹ Georgia Institute of Technology; Article attributed to Robert Michelson, gtresearchnews.gatech.edu/reshor/rh-spr97/microfly.htm. Accessed: February 10, 2001.

¹² Brophy, Christopher, Interviewed by Dr. Robert Frederick, Huntsville, AL. April 13, 2001

¹³ Eidelman, S. and Grossman, W., "Pulsed Detonation Engine – Experimental and Theoretical Review," AIAA Paper AIAA 92-3168, AIAA/SAE/ASME/ASEE Joint Propulsion Conference and Exhibit, Nashville, TN, July 6-8, 1992.

¹⁴ Moser, Marlow. Interviewed by Tim Hardin. Huntsville, AL, April 2001.

¹⁵ Bussing, T. and Pappas, G., "An Introduction to Pulse Detonation Engines," 32nd Aerospace Sciences Meeting and Exhibit, Reno, NV, January 10-13, 1994.

¹⁶ <http://www.fuelcells.org>. Accessed April 10, 2001.

¹⁷ Beziau, Jean Jacques, Centre d'Energetique de l'Ecole des Mines de Paris. "Systemes de piles a combustible pour la cogeneration," October 31, 1998.

¹⁸ Little, Arthur D., "PEM Fuel Cell Technology for Transportation Applications" Status and prospects, 1996.

¹⁹ <http://www.blador.com/information>. Accessed April 14, 2001.

²⁰ Mr. Bonofos teacher and Dean of the Motor engine laboratory at SUPELEC Paris

²¹ DeSeversky, Alexander. Ioncraft. United States Patent and Trademark office. U.S. Patent No. 3,130,945. April 28, 1964.

²² Fantel, Hans, "Major de Seversky's Ion Propelled Aircraft", *Popular Mechanics*. August 1964.

²³ <http://technology.ksc.nasa.gov/wwwaccess/techreports/97/07-EI/ei07.html> accessed 10 April 2001